



100 Series 45° Fill Valve With Bus and Truck Nozzle

Application

CNG and Bio-Gas Dispenser for Bus and Truck filling



FV103-4-02A-C 45° Fill Valve & NC104-200 Nozzle

Features & Benefits

The Oasis Full Flow Fill Valve with Bus & Truck Fuelling Nozzle redefines the flow rate standard for NGV gas delivery.

Hardened segment connection nozzle increases gripping surface area and reduces wear in receptors.

Green indicator shows nozzle in coupled position.

Both Fill Valve & Nozzle serviceable onsite with Oasis Service Kits.

The FULL FLOW design means more gas is dispensed faster to the vehicle, maximising the number of vehicle fills per day and minimising wasted gas.

Product Information

All products are manufactured under ISO 9001 accredited standards.

Fill Valve designed to ANSI/CGA NGV1 Standard.

Bus & truck fuelling nozzle designed and tested to ISO 14469-2 Standard

Fill valve complies with PED 97/23/EC

Nozzle to fit DN12 (C200) receptacles as per ISO 14469-2 Standard.

Video servicing instructions available online at oasisngv.com/resources



Example of Receptacle DN12



100 Series 45° Fill Valve With Bus and Truck Nozzle

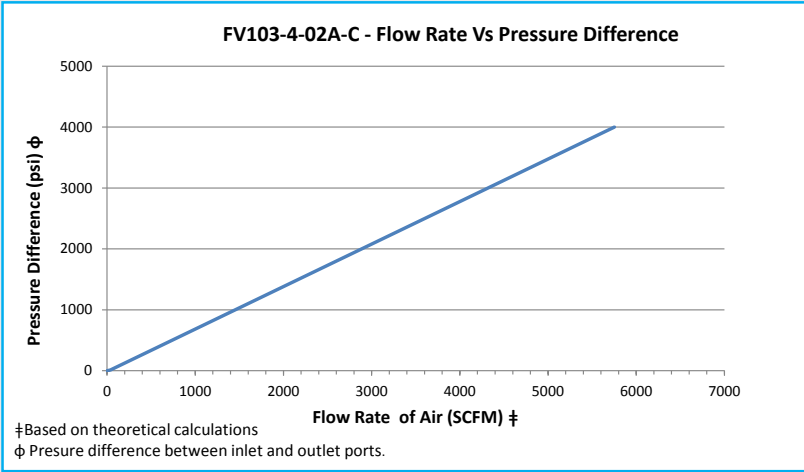

Dimensions

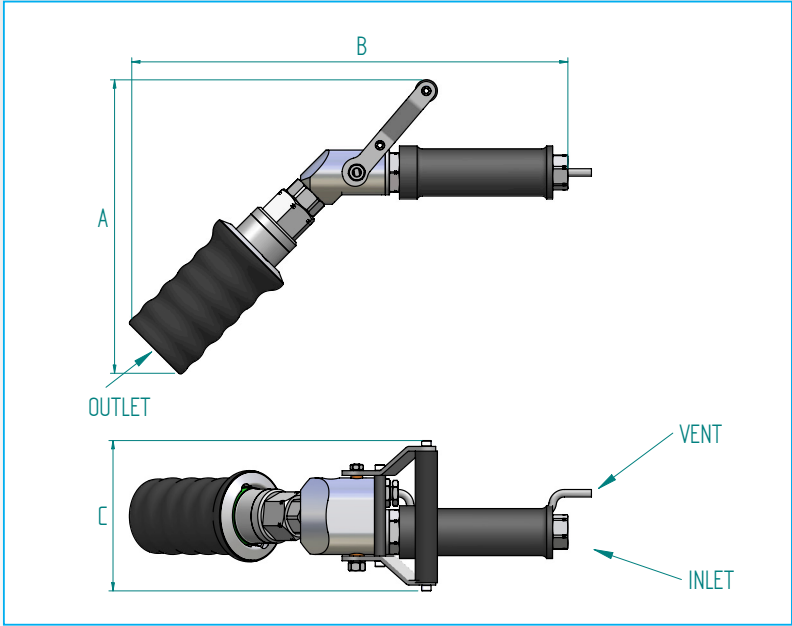

Dimensions (mm)

Part Code	A	B	C	Inlet Port	Vent Line	Outlet
FV103-4-02A-C	250	370	128	3/4 - 16 SAE	1/4" Tube	NC104-200

Product Specification

Part Code	Size	Mass Kg (lb)	Service Pressure Psi (bar) *	Test Pressure Psi (bar) **	Min. Temp. °C (°F)	Max. Temp. °C (°F)	Stem Open Torque Nm (ft/lb)	Cycles Before Rekit ^	Cv	Nozzle Service Kit ^^	Fill Valve Service Kit
FV103-4-02A-C	3/8"	3.3 (7.2)	3600 (248)	5400 (400)	-40 (-40)	85 (185)	5 (3.7)	100,000	2.4	NC104-SK200-1	FV103-SKDN

We reserve the right to modify product specifications without prior notice.



100 Series 45° Fill Valve With Bus and Truck Nozzle

Service Kits

All wearing components are available for replacement with original Oasis service kits

FV103-SKDN

Fill valve service kit for sealing components, recommended to be replaced on or before the maximum cycles before re-kit as identified in product specifications.



NC104-SK200-1

Bus and truck nozzle service kit, recommended to be replaced on or before the maximum cycles before re-kit as identified in product specifications



NC104-SK200-1 service kit for NC104-200 nozzle only.

FV103-17

Fill valve 2 piece handle sleeve, to be replaced as required



FV103-70

Fill valve handle replacement kit, to be replaced as required

