



Sanitary 3 Way Shutter Valve

Features & Benefits

Used in the New Zealand Dairy Industry for over a quarter of a century, proven quality, readily available replacement kits, it's just kept on working.

The fully machined and polished food contact surfaces are factory checked to meet the required surface smoothness, typically Ra of 0.80µm (32µin). Minimising loss due to product spoil.

Adjustable shutter tensioning system for complete sealing and even shutter contact

Optional handle positioner for ¼ or ½ turn action to suit most actuation systems

Minimal flow disturbance for foam prevention.

Excellent cleaning capabilities including clean in process optional adaption (pictured)



Materials

DESCRIPTION	MATERIAL
Valve body	316 Stainless Steel
Shutter	PRFE
Seals	Nitrile

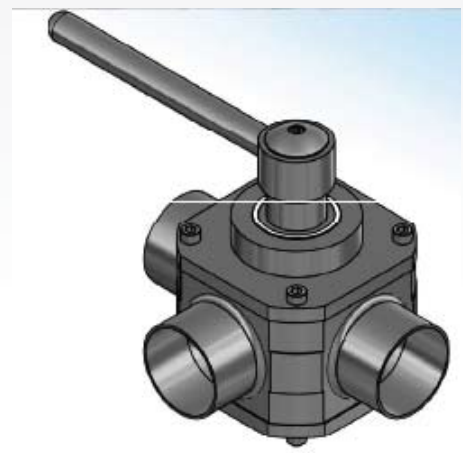



Sanitary 3 Way Shutter Valve

Applications and Specifications Information

Used extensively throughout NZ for over a quarter of a century for milk vat applications.

Suitable for all food service applications.

The fully machined and polished food contact surfaces are factory checked to meet the required surface smoothness, typically Ra of 0.80µm (32µin).

MAF Centrefeed.

Clean In Process (CIP) fittings available on request.

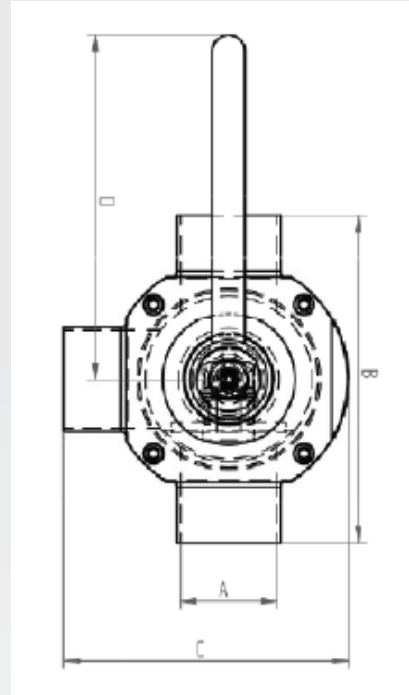

Dimensions

PART CODE	A	B	C	D
PC338	38	141	146	130
PV350	50	162	168	170
PV376	76	187	226	190

- Max Pressure Against Shutter:
- 4 BAR (60PSI)
- Max Temperature:
- 110° C (255°F)
- All products are manufactured to ISO 9001:2000 standards
- "Clean in process" fitting available on request.