



100 Series Bus/Truck Nozzle

Applications

Refuelling nozzle for high flow CNG and Bio-Gas applications such bus, truck & trailer filling.



NC104-200 - Bus/Truck Nozzle

Features & Benefits

Hardened segment connection style increases gripping surface area. This significantly reduces wear on male coupling.

Stainless steel construction gives corrosion and wear resistance.

Easily serviceable onsite with Oasis Service Kit.

Green indicator shows coupled position.



Example of Receptacle DN12

Product Information

All products are manufactured under ISO 9001 accredited standards.

Class A tested to 100,000 + cycles.

Designed to Fit DN12 (C200) Receptacles as per ISO 14469-2 Standard.

Nozzle designed & Tested to ISO 14469-2 (2007) Standard.

Complies to PED 2014/68/EU.

Video servicing instructions available online at oasisngv.com/resources.

Materials

Item	Part	Material
1	Body	316 Stainless Steel
2	Coupler Nose	316 Stainless Steel
3	Sleeve	6061 Aluminium
4	Poppet	316 Stainless Steel
5	O-rings	Nitrile
6	End Cap	316 Stainless Steel
7	Segments	420 Stainless Steel
8	Ball Bearings	420 Stainless Steel



100 Series Bus/Truck Nozzle

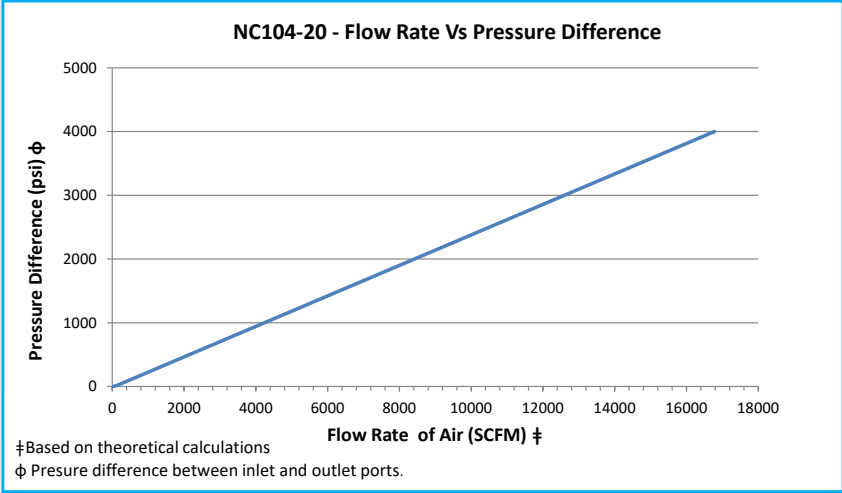

Dimensions

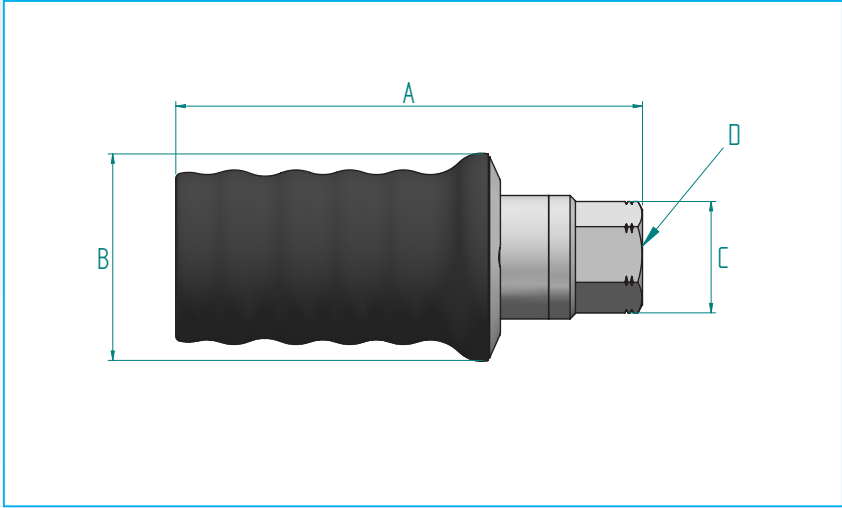

Dimensions (mm)

Part Code	Size	A	B	C (A/F)	D (Inlet Port)
NC104-200	DN12	174	77	36	7/8 -14 SAE

Product Specification

Part Code	Mass kg (lb)	Service Pressure psi (bar) *	Max. Test Pressure psi (bar) **	Min. Temp. °C (°F)	Max. Temp. °C (°F)	Cycles Before Rekit ^	Cv	Nozzle Service Kit ^^
NC104-200	1.8 (4)	3600 (248)	5400 (372)	-40 (40)	85 (185)	100,000	7	NC104-SK200-1

* System pressure that the product is designed for.
 ** Maximum static pressure that can be applied without affecting the operation of the product.
 ^ It is recommended that the nozzle is re-kitted on or before the maximum number of allowable cycles.
 ^^ NC104-SK200 service kit for NC104-200 nozzle only. For NC104-C200 use NC104-SK service kit only.

We reserve the right to modify product specifications without prior notice.