



100 Series 180° Fill Valve With NGV1 Nozzle

Applications

CNG and Bio-Gas dispenser for car, bus and truck filling & CNG and Bio-Gas trailer load/unload systems.



FV103-0-AD6-G - 180° Fill Valve & P36 NGV1 Nozzle

Features & Benefits

The Oasis full flow fill valve & fueling nozzle redefines the flow rate standard for NGV gas delivery.

Intuitive fill valve and nozzle operation.

All Oasis fill valves and nozzles are easily serviced in the field using Oasis's product specific service kits.

Adaptors are available to extend the position of the nozzle.

Product Information

All products are manufactured under ISO 9001 accredited standards.

The FULL FLOW design means more gas is dispensed faster to the vehicle, maximising the number of vehicle fills per day and minimising wasted gas.

Nozzle tested to ANSI/CGA NGV1 standard.

Complies to PED 2014/68/EU.

Video servicing instructions available online at oasisngv.com/resources.



100 Series 180° Fill Valve With NGV1 Nozzle

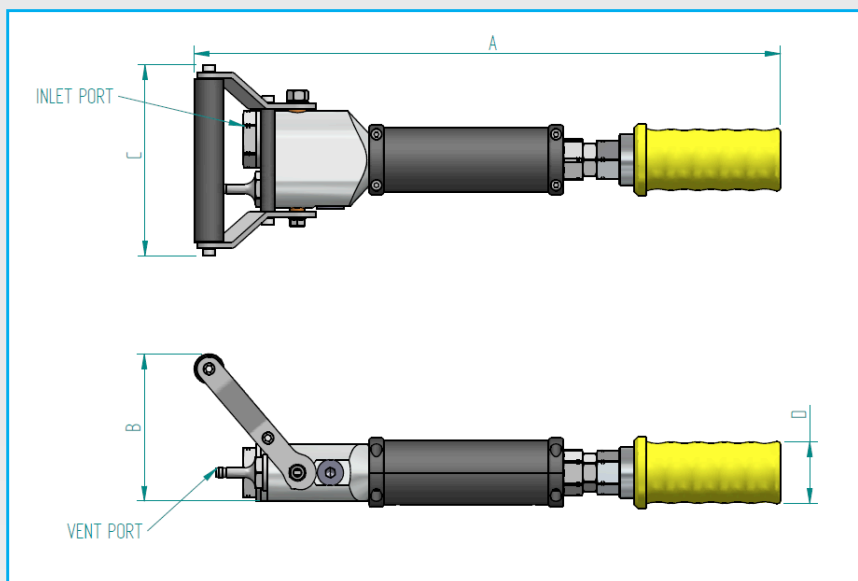

Dimensions Inch (mm)

Part Code	Size	A	B	C	D	Inlet Port	Vent Port	Outlet
FV103-0-AD6-F	3/8"	15.4 (392)	3.86 (98)	4.9 (128)	1.6 (41)	9/16-18 SAE Female	1/4" Male Tube Stub	NGV1 P30
FV103-0-AD6-G	3/8"	15.4 (392)	3.86 (98)	4.9 (128)	1.6 (41)	9/16-18 SAE Female	1/4" Male Tube Stub	NGV1 P36

Product Specification

Part Code	Mass kg (lb)	Service Pressure psi (bar)*	Max. Test Pressure psi (bar)**	Min. Temp. °C (°F)	Max. Temp. °C (°F)	Stem Open Torque Nm (ft-lb)	Max Cycles Before Rekit ^	Cv	Nozzle Service Kit	Fill Valve Service Kit
FV103-0-AD6-F	2 (4.4)	3000 (206)	5400 (400)	-40 (-40)	85 (185)	5 (3.7)	100,000	1.9	NC203-SK1	FV103-SKDN
FV103-0-AD6-G	2 (4.4)	3600 (248)	5400 (400)	-40 (-40)	85 (185)	5 (3.7)	100,000	1.9	NC203-SK1	FV103-SKDN

* System pressure that the product is designed for.

** Maximum static pressure that can be applied without affecting the operation of the product.

^ It is recommended that the nozzle and fill valve are re-kitted on or before the maximum number of allowable cycles.



100 Series 180° Fill Valve With NGV1 Nozzle

Service Kits

All wearing components are available for replacement with original Oasis service kits.

FV103-SKDN

Fill valve service kit for sealing components, recommended to be replaced on or before the maximum cycles before re-kit as identified in product specifications.



NC203-SK1

NGV1 P30/P36 nozzle service kit, recommended to be replaced on or before the maximum cycles before re-kit as identified in product specifications.



FV103-17

Fill valve 2 piece handle sleeve, to be replaced as required.



FV103-70

Fill valve handle replacement kit, to be replaced as required.

