



# 900 Series TPED Trailer Manifold

## Applications

High flow TPED trailer load/unload manifold.

Suitable for Hydrogen, CNG, RNG, Biogas, Helium, Nitrogen and other gases on enquiry.

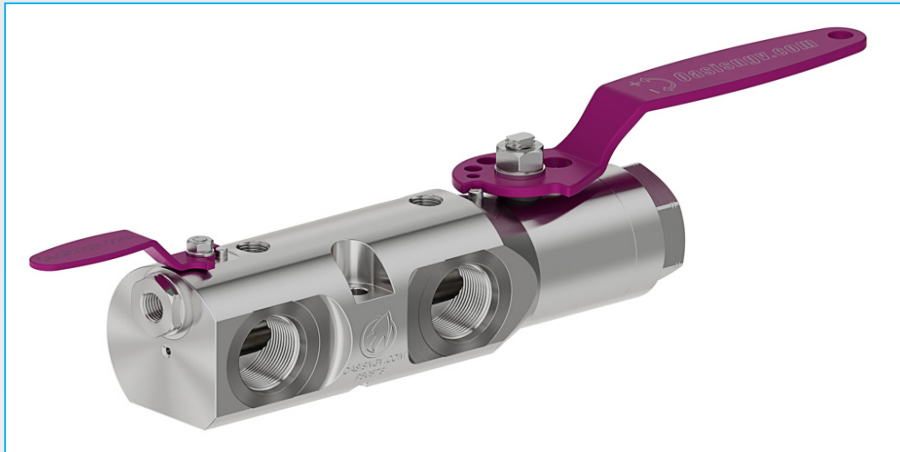

TM908-6S6TCDW-G000

## Materials

Item	Part	Material
1	Body & Cap	Stainless Steel
2	Ball	Stainless Steel
3	Stem	Stainless Steel
4	Seats	PEEK
5	Thrust washer	POM

Item	Part	Material
6	Gland	POM
7	O-rings	FKM
8	Backup rings	NBR
9	Handle	Stainless Steel

## Product Information

Type tested to ISO23826.

Complies with TPED 2010/35/EU.

CRN pending.

All products are manufactured to ISO 9001 standards.

SAE threads conform to SAE J1926.

Other connections available on request.

Custom handles available on request.

End users shall consider the pressure and flow of the system to which the valves are installed.

## Features & Benefits

Suitable for 385 bar working pressure trailers.

Easy to service, kits readily available.

Quarter turn handle.

Anti blow-out stem.

Manufactured from certified bar stock.

Lockout system available to prevent accidental operation of valve.

Can be manufactured to your specifications, contact us for details.



# 900 Series TPED Trailer Manifold

## Product Specification

Part Code	Size (DN) Inch (mm)	Handle Lock out	Mass lb (kg)	Lowest Operating Pressure bar (psi) *	Working Pressure (WP) bar (psi) **	Max Allowable Working Pressure (PT) bar (psi) ***	Min. Temp. °F (°C)	Max Temp. °F (°C)^^^	Cycles Before Rekit^	Stem Open Torque ft-lb (Nm)^^^	Cv	Service Kit
TM908-6S6TCDW-G000	1 (25.4)	No	13.2 (6)	6.9 (100)	385 (5584)	462 (6700)	-40 (-40)	149 (65)	2000	33.2 (45)	15.8	TM908-SK1-S8

- \* Lowest settled gas pressure for which the ball valve is designed. This is the minimum pressure that the product will hold constant bubble tight seal.
- \*\* Settled pressure of a compressed gas at a uniform reference temperature of 15°C in a full pressure receptacle for which the valve is intended.
- \*\*\* Minimum pressure applied to the valve during testing
- ^ The temperature's and cycles stated depend on the system conditions and may not be achievable in all situations. Contact Oasis for further information.
- ^^ Maximum opening torque at maximum operating pressure.
- ^^^ TPED-certified to 65 °C, evaluated by Oasis to 85 °C, which exceeds certification scope and must be verified by the system designer. Contact Oasis for further information.

## Product Dimensions

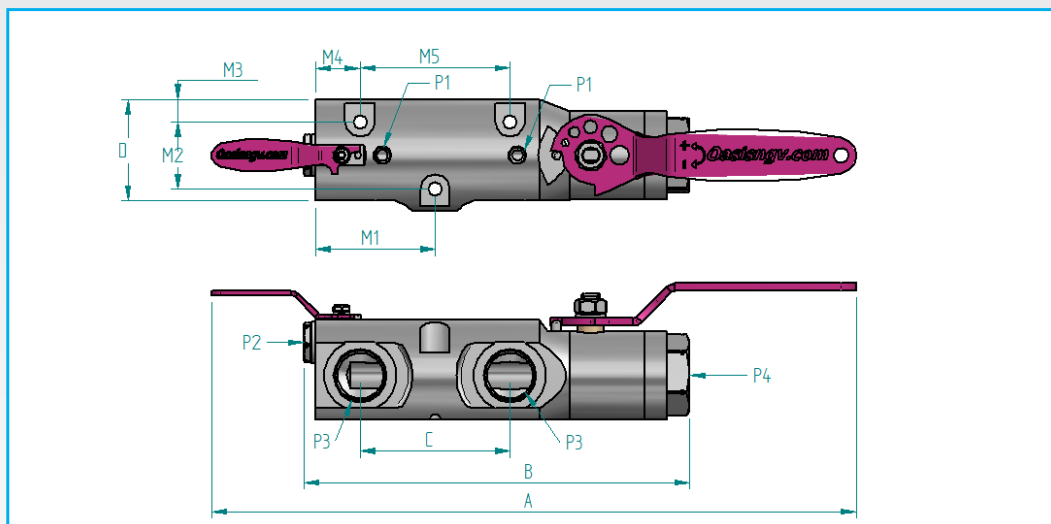

## Product Dimensions - Inch(mm)

Part Code	A	B	C	D	E	F	PORT P1	PORT P2	PORT P3	PORT P4
TM908-6S6TCDW-G000	16.94" (430)	10.15" (258)	3.93" (100)	3.6" (91.5)	3.4" (86)	2.95" (75)	1/4" NPT Female	1/4" NPT Female	1 5/16-12" SAE Female	1 5/16-12" SAE Female

Other connection configurations available on request, contact Oasis for further information.

## Mounting Dimensions: Inch (mm)

Part Code	M1	M2	M3	M4	M5	Mounting hole diameter
TM908-6S6TCDW-G000	3.15" (80)	1.77" (45)	.59" (15)	1.18" (30)	3.94" (100)	.35" (9)

## P&ID

- P1 = Gauge Port/Spare Gauge Port
- P2 = Vent Port
- P3 = To/From Storage
- P4 = To/From Storage

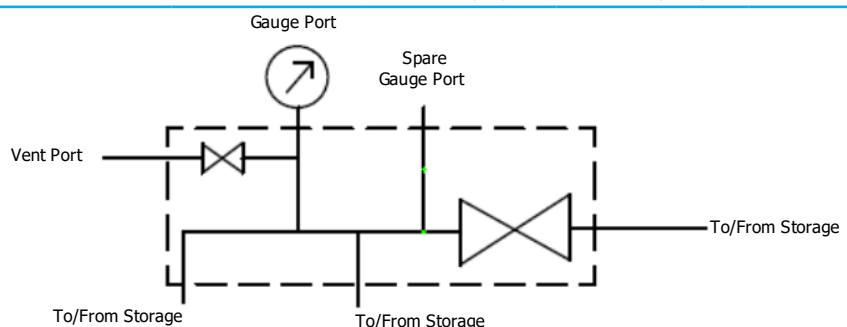

We reserve the right to modify product specifications without prior notice.