



TH900 Series Cylinder Valve Instruction Manual

▲ WARNING

Failure to follow these instructions or to properly install and maintain this equipment could result in gas leakage, fire or explosion causing property damage and personal injury or death.

Oasis products must be installed, operated and maintained by trained and competent personnel in accordance with all applicable local codes, rules and regulations in addition to the Oasis Instructions.

Oasis Engineering Ltd. will not be held liable in such circumstances where installation, operation and maintenance procedures were performed by incompetent personnel resulting in improper assembly, unsafe operation, equipment damage or personal injury.

Oasis Engineering Ltd
129 Birch Avenue, Tauranga, New Zealand.
T: +64 7 928 3808
E: info@oasisNGV.com
W: www.OasisNGV.com



Instruction Manual

Warning!

High pressure gas and gas equipment can cause serious harm to both infrastructure and personnel if safety precautions are not followed.

Oasis recommends considering the use of the following PPE when working with high pressure along with any other site specific health and safety requirements:



Foot Protection



Hearing Protection



Safety Helmets



Hand Protection



Safety Glasses



Ensure the system is clean of debris, vented and isolated before any installation or servicing work is carried out.

Attention!

Oasis 900 series cylinder valves are intended for use with gaseous Hydrogen, CNG, Helium, Biogas or Nitrogen.

Tools Required

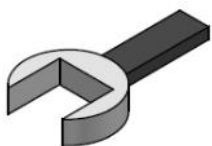

Spanner
(Wrenches)



Anti Seize Grease
- Swagelok Silver Goop
- Omega 99
- or similar



Spray bottle
(Snoop or soapy water)

1. Attach adaptor to tank, applying anti-seize to large thread, grease to large O-ring and torque to 100Nm

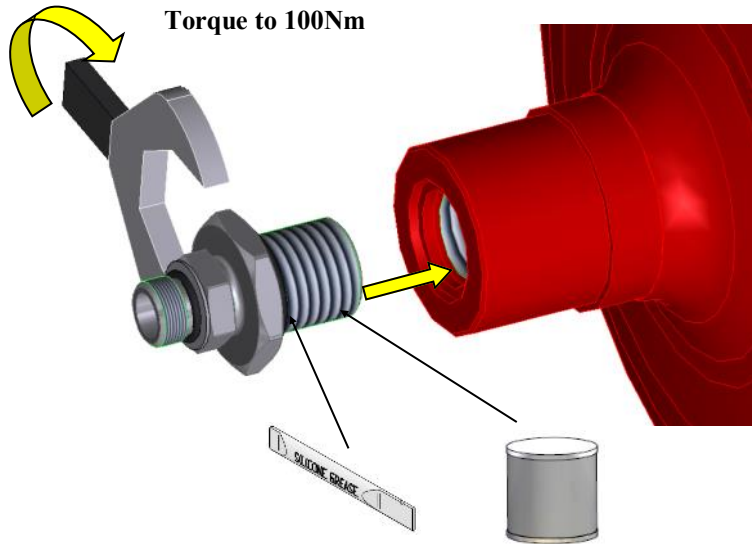

2. Back off lock nut as far as possible. Push back up washer and O-ring down as far as possible.

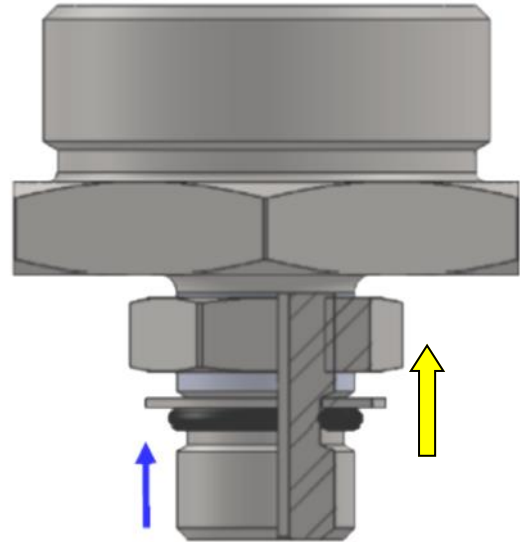

3. Apply anti-seize to adaptor thread then screw body fully onto adaptor by hand.

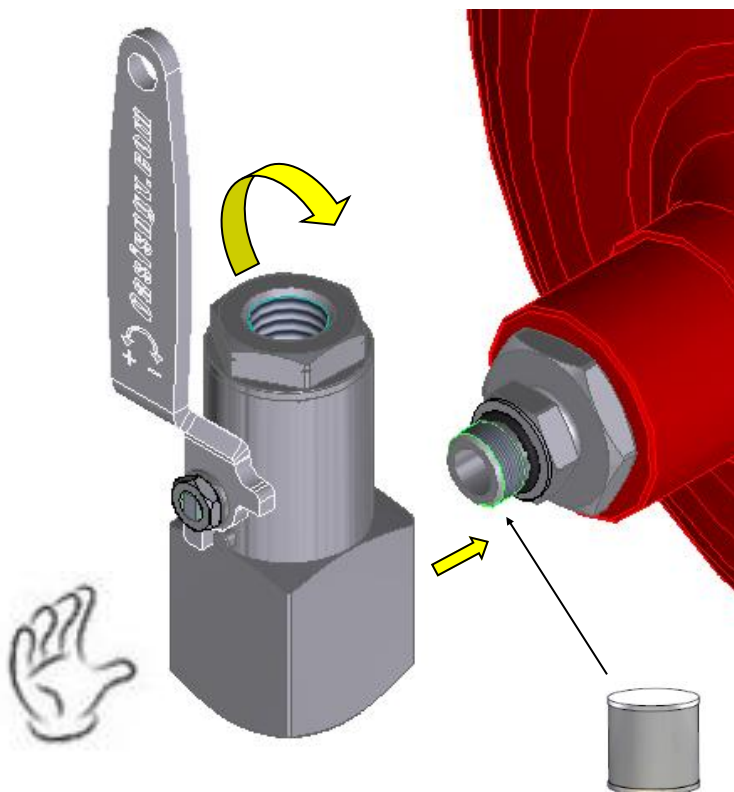

4. Align valve by unwinding no more than one turn. Screw adjustable nut out until it contacts washer.

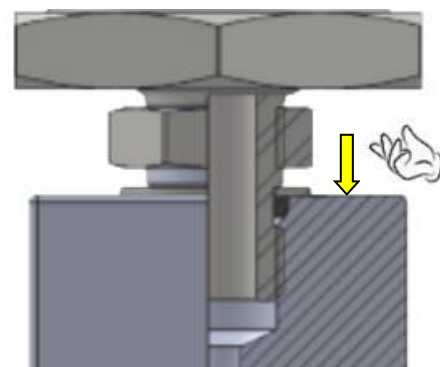
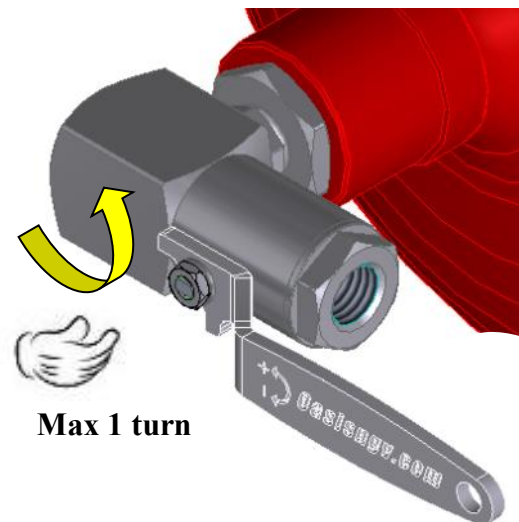

5. Using 2 wrenches, tighten lock nut to 50Nm.

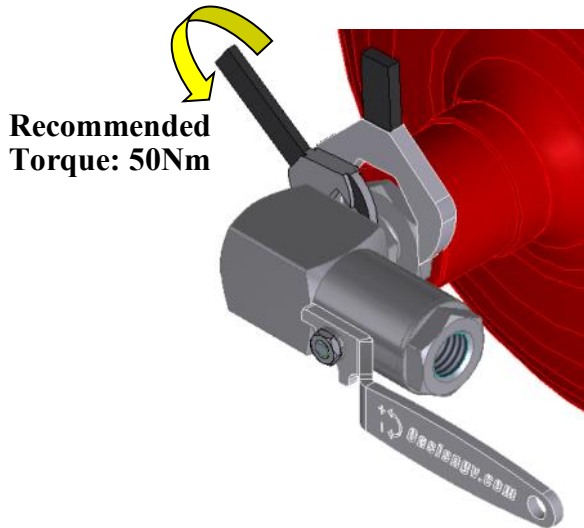

6. Apply anti-seize to fitting thread and attach fitting to outlet.

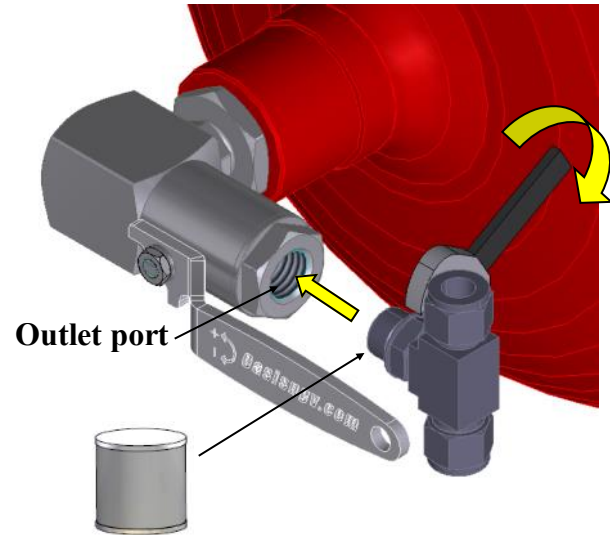

7. Apply anti-seize to thread of live port fitting and tighten end connection.

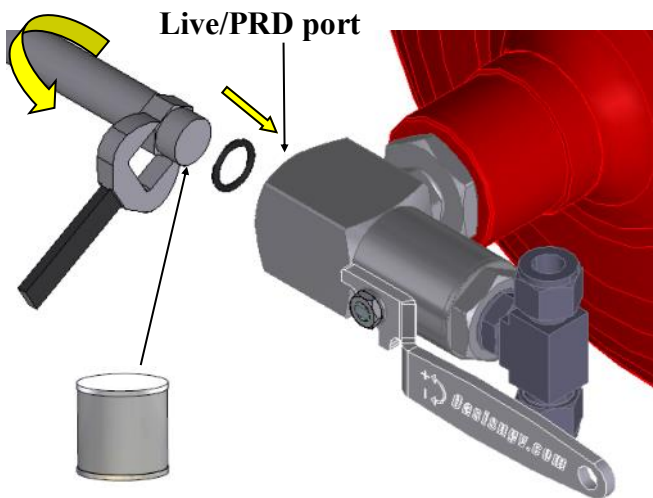

8. Test all joints for leakage during first use with Snoop or soapy water.

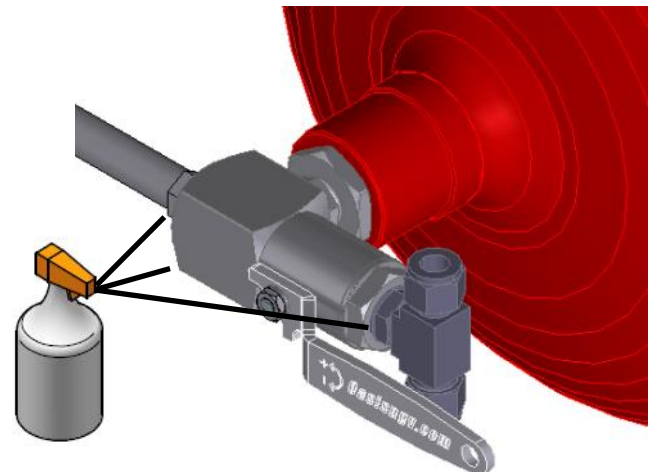

Recommended Spanners for:

Hex End Cap (A/F) = 34mm

Stem Nut (A/F) = 13mm

Adaptor (A/F) = 42mm

Adaptor Positional Hex Nut (A/F) = 26mm

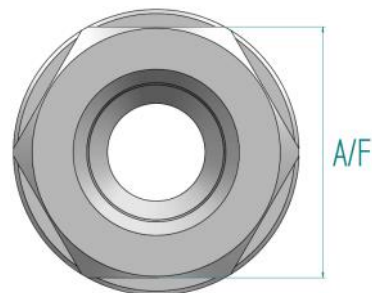

1. Open



2. Closed

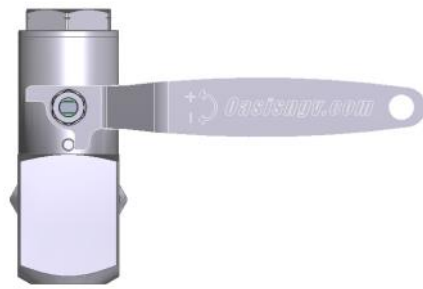

Important: Actuate valve 4 times before use to ensure initial sealing.

Optional - Main valve Lock-plate & Carabiner In Open Position

Optional - Main Valve Lock-plate & Carabiner In Closed Position

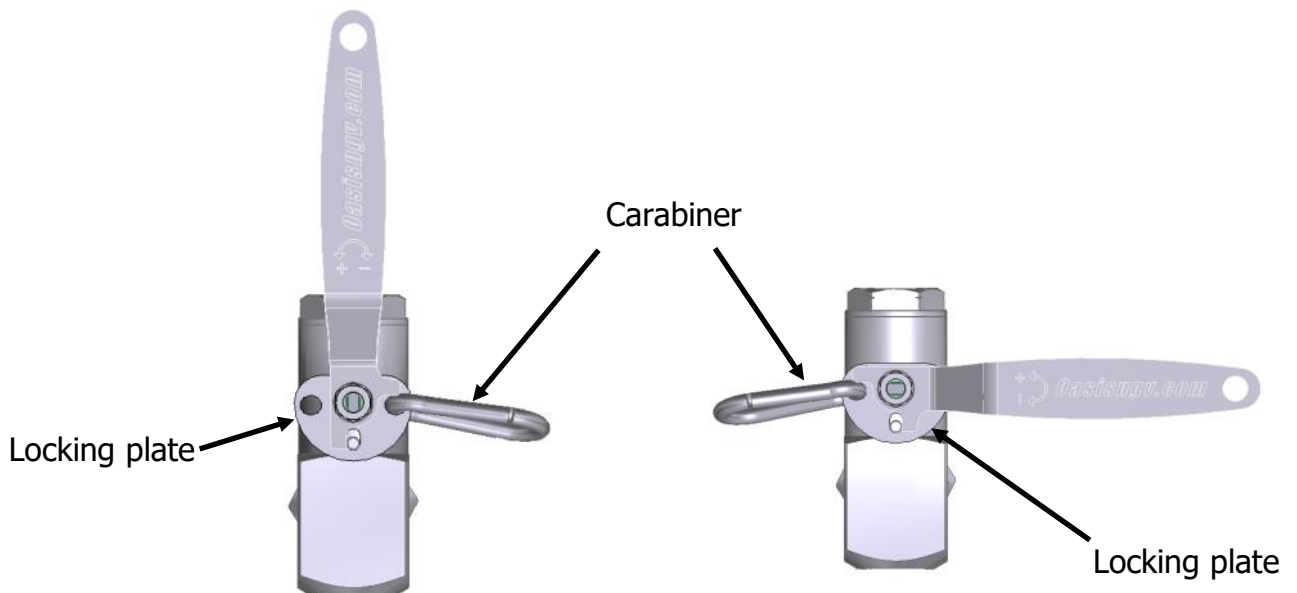

The carabiner is placed through the appropriate hole on the locking plate when the handle is in the desired position. Movement of the handle is prevented until carabiner is removed.

Service Kit Parts



The Complete Oasis Seal Kit must be used

Tools Required

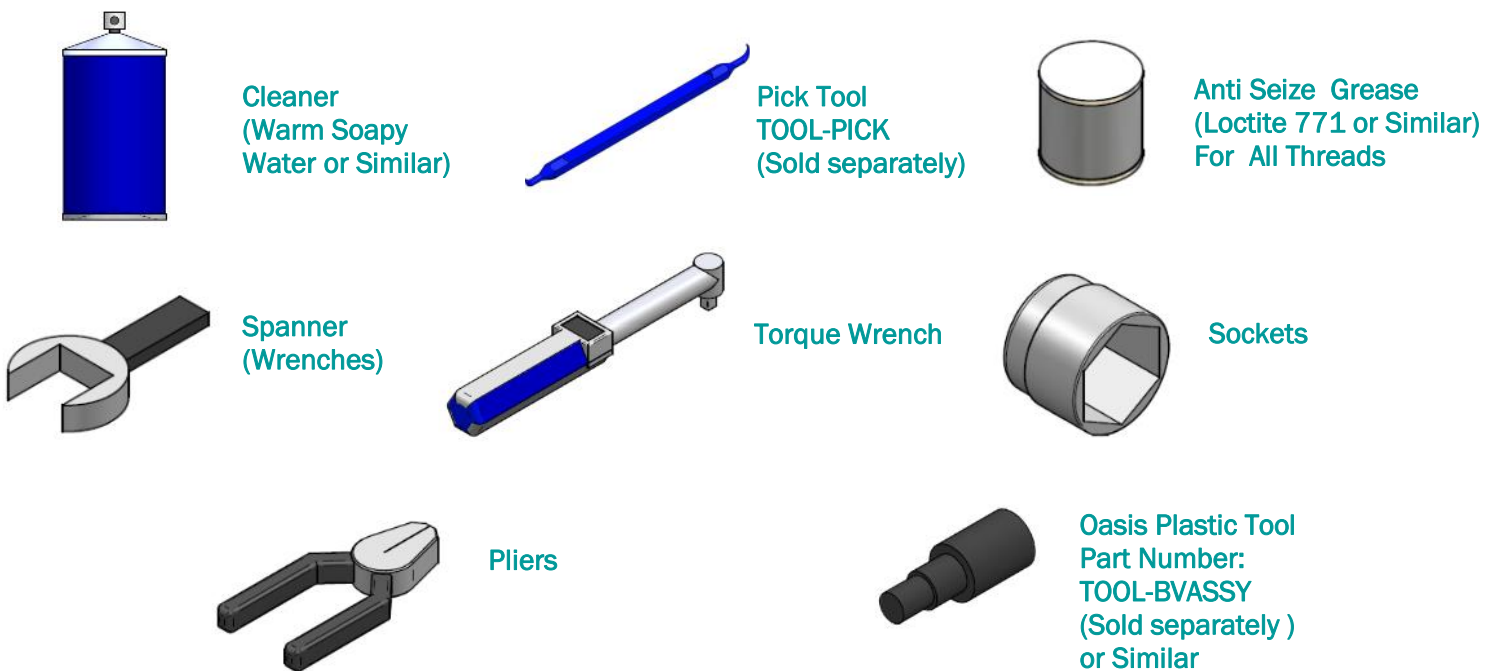

1. Vent pressure from system and remove valve.

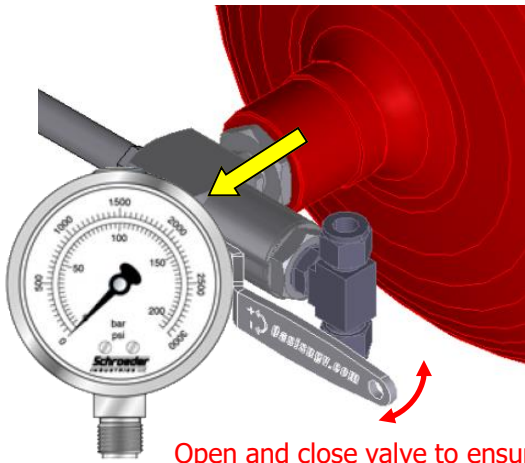

Open and close valve to ensure all trapped gas is released

2. Remove adaptor.

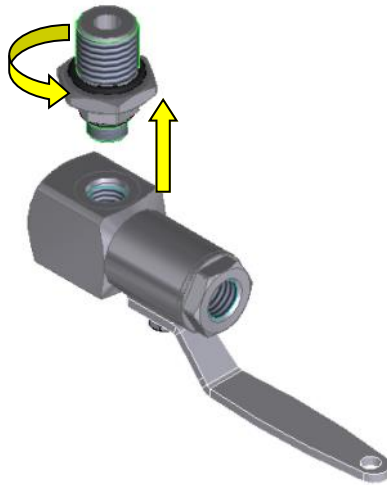

3. Discard adaptor O-rings.

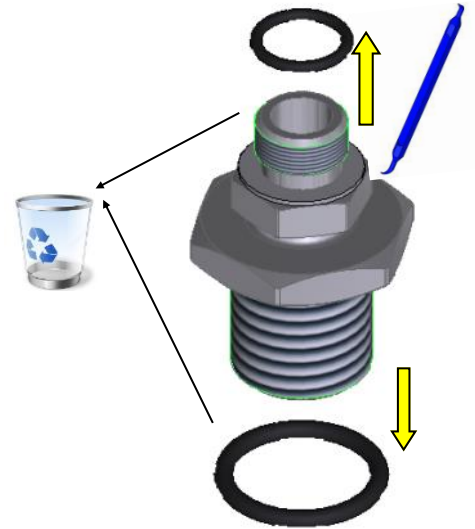

4. Remove handle.

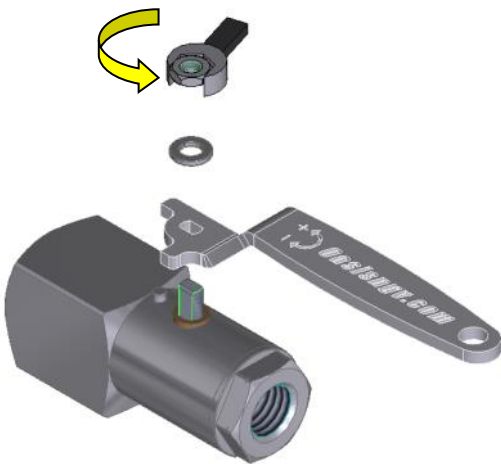

5. Discard gland.

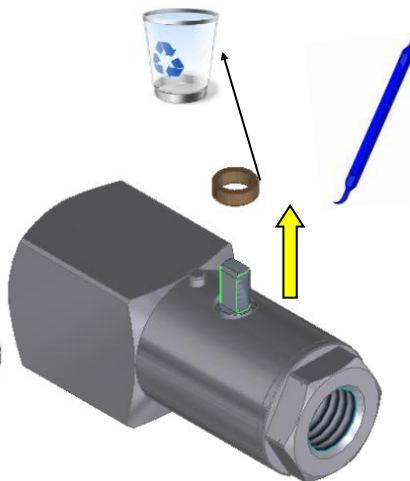

6. Remove end cap.

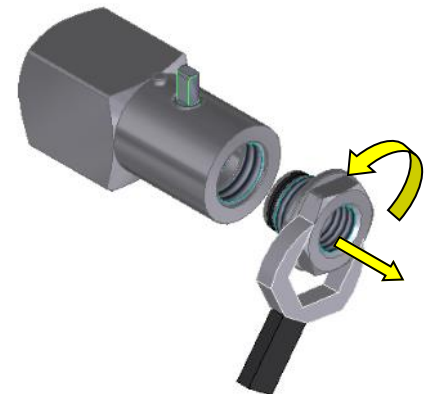

7. Discard the seat.

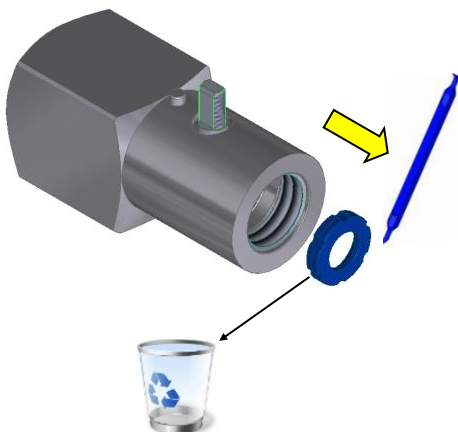

8. Discard the ball.

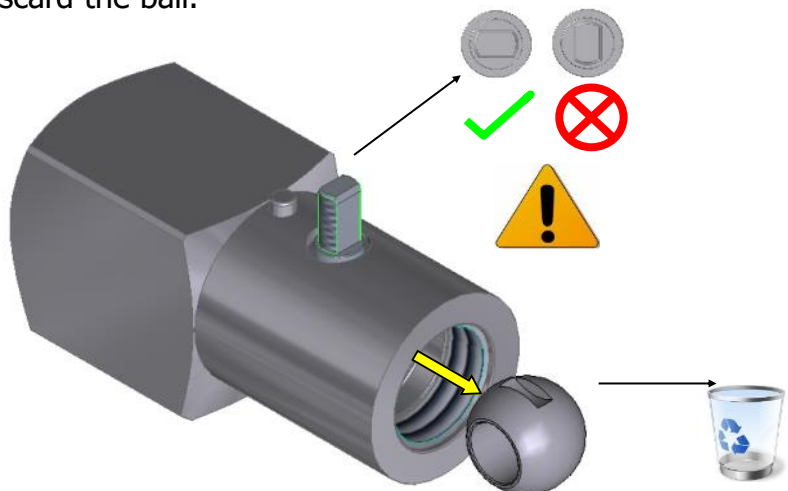

9. Discard the stem.

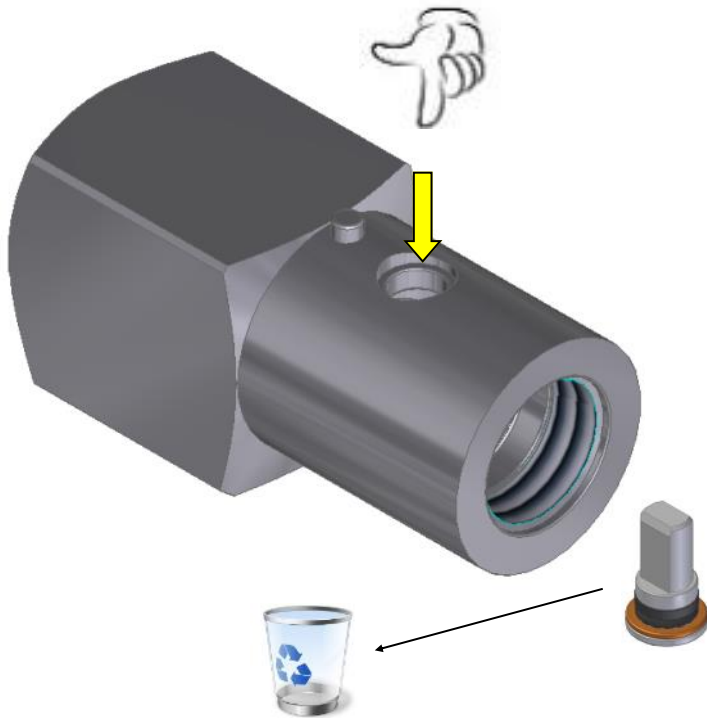

10. Discard the second seat.

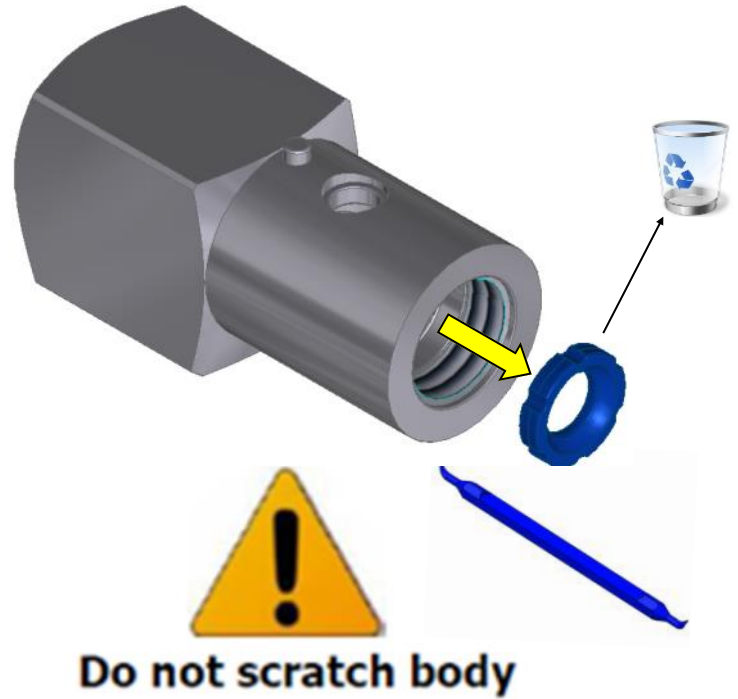

11. Discard the cap O-rings.

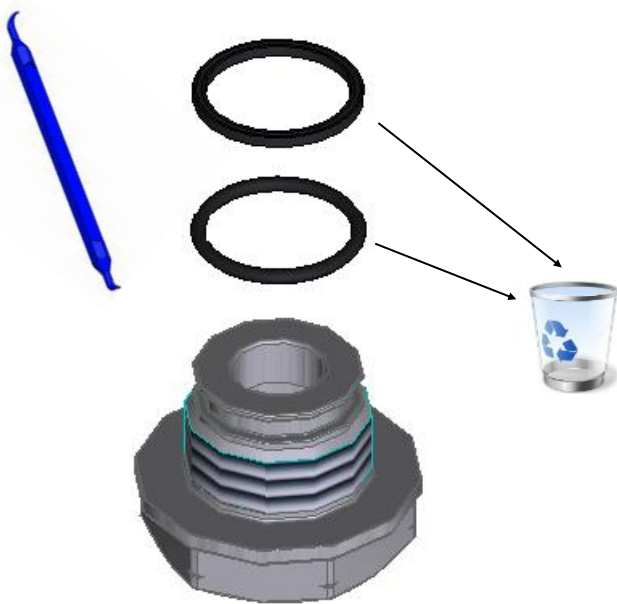

12. Clean the components and inspect for damage.

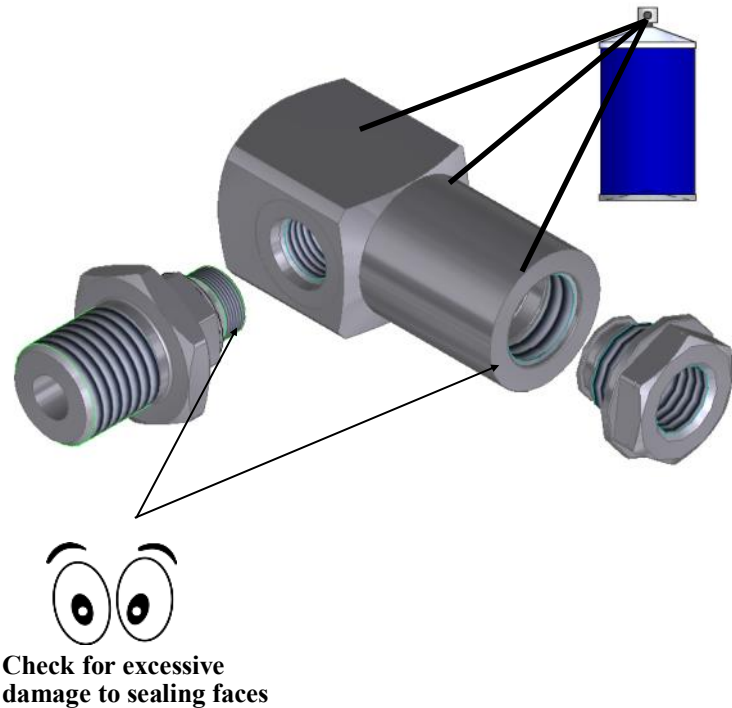

1. Insert 1st seat.



2. Apply grease to the stem O-ring and insert stem assembly.



3. Insert ball.

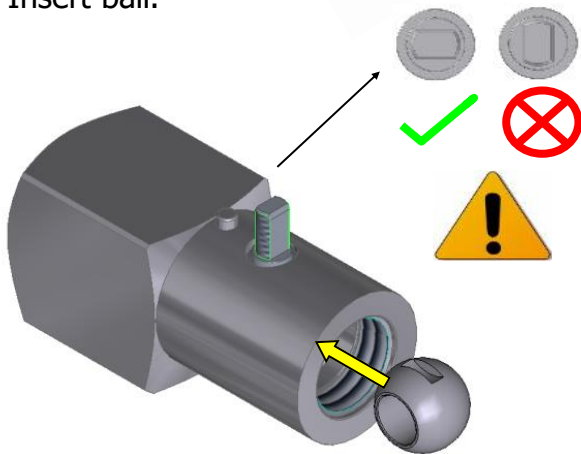

4. Insert 2nd seat.

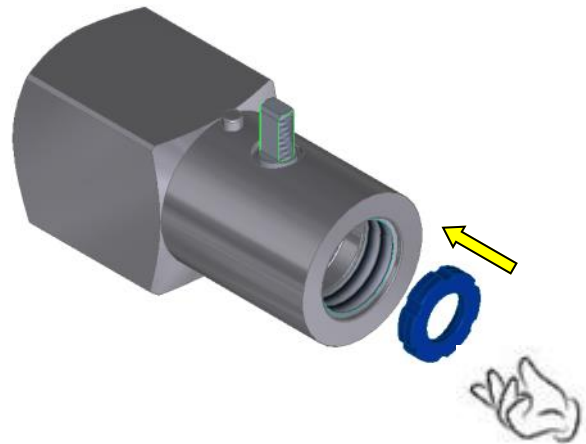

5. Grease & fit cap O-rings. Apply anti-seize to thread.

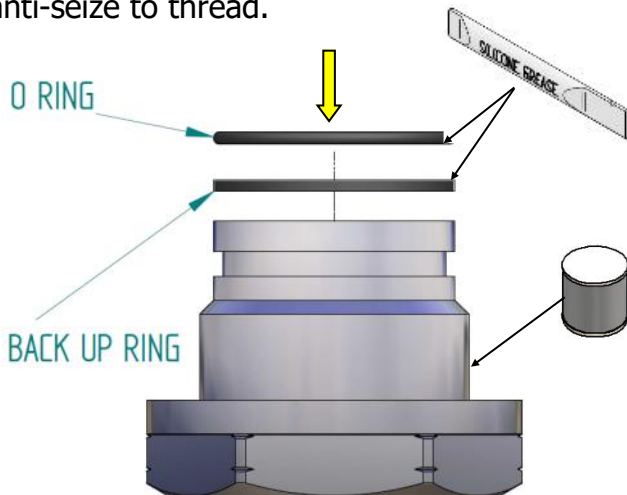

6. Tighten end cap.

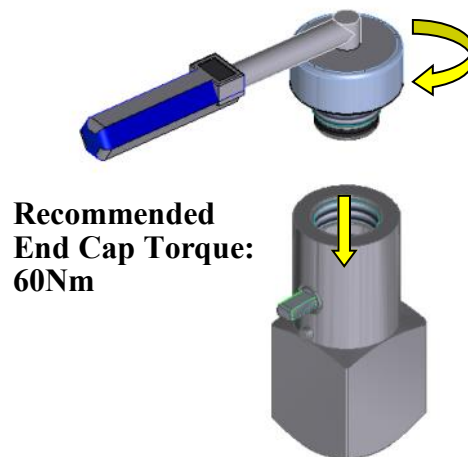

Recommended End Cap Torque: 60Nm

7. Insert gland.

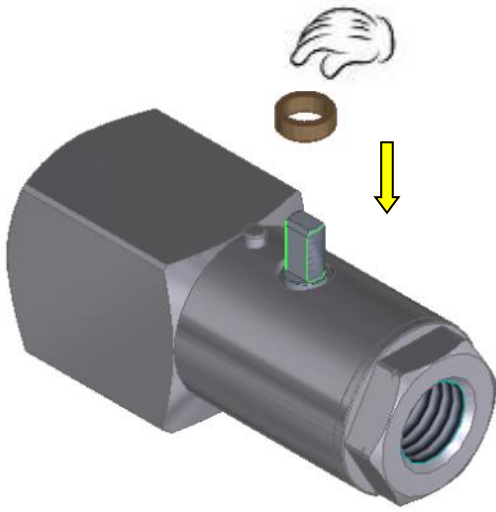

8. Assemble handle components.

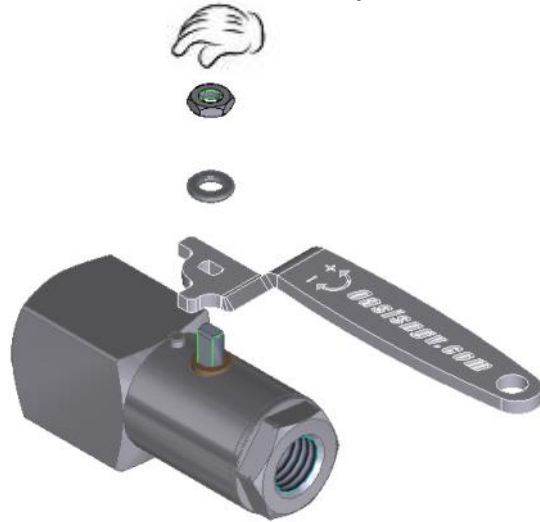

9. Tighten handle nut.

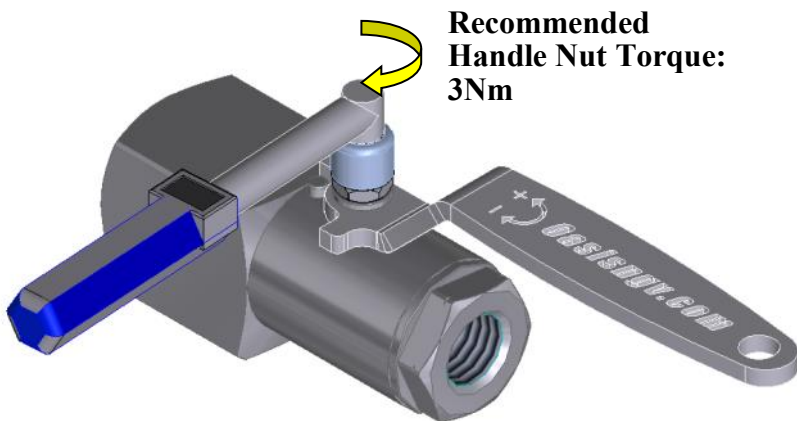

10. Apply grease O-rings and fit to adaptor.

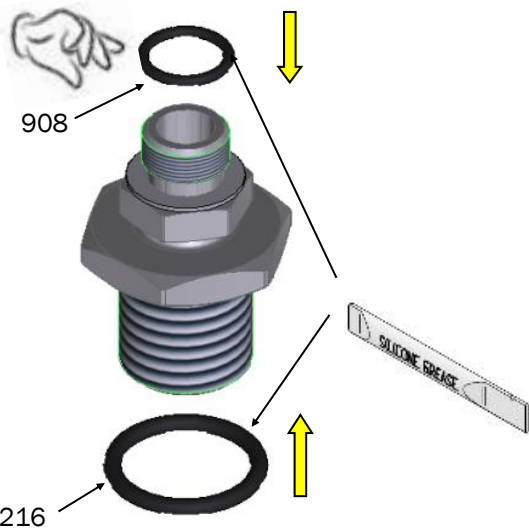

11. Apply anti-seize to threads.

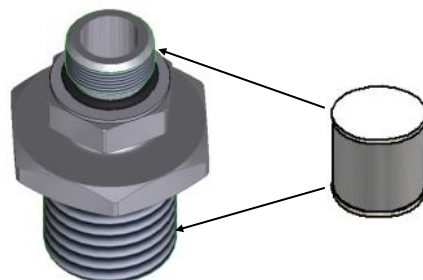

12. Follow installation instructions on page 3 of this manual for re-fitment of valve. Replace SAE port O-rings with those supplied in service kit.

Apply silicone grease to all O-rings and anti
seize to all threads

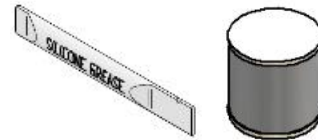

Fit small SAE port O-ring (906)

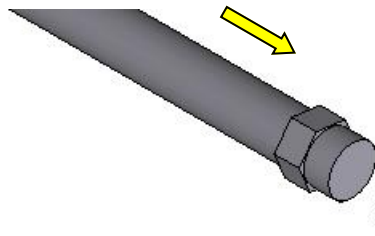

Fit medium SAE port O-ring (908)

